

# TABLE OF CONTENTS

## *Model SF-1 Ribbon Microphone*

Table of Contents	page 1
Introduction	page 2
Description	page 2
Applications	page 2
Users Guide: Using the SF-1	page 3
Amplification Considerations	page 4
The Sweet Spot Finding & Working with the “Sweet Spot”	page 7
Other Types of Microphones	page 8
Proximity Effect & Working Distance	page 9
Microphone Technique	page 9
Stereophonic Microphone Technique	page 10
Care & Maintenance	page 13
A Little Bit of History	page 13
Features & Specifications	page 14
Electrical Specifications	page 15
Mechanical Specifications	page 15
Polar Pattern & Frequency Response	page 15
Warranty	page 16

## ***Introduction***

Congratulations on your purchase of a Royer Labs model SF-1 ribbon microphone. The SF-1 is a handcrafted precision instrument capable of delivering superior sound quality and overall high performance.

This operator's manual describes the SF-1, its function and method of use. It also describes the care and maintenance required to ensure proper operation and long service life. The users guide section of this manual offers practical information that is designed to maximize the performance capabilities of this microphone.

Royer Labs products are manufactured to the highest industrial standards using only the finest materials obtainable. Your model SF-1 went through extensive quality control checks before leaving the factory. Normal care, given to any quality instrument, is all that is required to assure years of trouble-free service.

Please read the manual thoroughly in order to become familiar with all of the SF-1's capabilities. It will assist you in making the most of its superior acoustic properties. This owner's manual is a handy reference guide and we suggest you refer to it whenever questions arise on the use and care of your SF-1 ribbon microphone.

## ***Description***

The Royer Labs model SF-1 is an ultra compact bi-directional (*figure-eight*) velocity type ribbon microphone designed for professional applications. The figure-eight pick-up pattern allows the SF-1 to be addressed from either side with equal sensitivity. The *in-phase* signal is achieved when the microphone is addressed from the front, indicated by the "ROYER" logo.

The SF-1 is very tolerant to shock and vibration, and is unaffected by changes in temperature or humidity. However, ribbon microphones are sensitive to direct blasts of air and the SF-1 is no exception to this rule. Discretionary use of a windscreen or pop-filter, such as the WS58, PS-100 or equivalent is highly recommended for situations such as close miking, especially with vocalists or certain types of percussion and wind instruments.

It is important to note that Royer ribbon microphones are known to be tough and durable. While all Royer's are built to last a lifetime, the thicker ribbon element in our R-121 ribbon mic can take more abuse than the finer, somewhat more delicate ribbon element in your SF-1. The SF-1 can handle over 130 dB SPL, while the R-121 can handle over 135 dB SPL. Please be aware of this as you use your SF-1. Handled with care, it will be many years before you need to re-ribbon your microphone (ribbons can last indefinitely if not abused.)

## ***Applications***

The Royer Labs model SF-1 is a versatile microphone and is ideally suited for many critical recording applications. Its smooth frequency response characteristics and ability

to capture detail make it a fine choice for many instruments, as well as for general broadcast applications. Its gentle low-frequency proximity effect makes it especially useful for announcers and vocalists. Female vocalists often benefit from the SF-1's ability to capture high frequencies without distortion or edginess. Orchestral instruments are captured in a very natural sounding way, free from microphone-induced "hype." The SF-1 has exceptionally smooth high frequency characteristics. Phase-related distortion and irregular frequency peaks are conspicuously absent. Theater organs and electric guitar amplifiers sound big and fat, without unnatural coloration, when reproduced with the SF-1. These features make the SF-1 ribbon microphone an ideal choice for strings, woodwinds, percussion and amplified instruments. Acoustic pianos can be captured accurately without the comb-filtering effects associated with condenser microphones.

## ***User's Guide***

### ***Using The SF-1 Ribbon Microphone***

#### ***Operation***

The SF-1 ribbon microphone is a versatile device capable of accurate sound reproduction. There are a few important facts about ribbon microphones that are key in understanding how to use them intelligently.

1. The SF-1 is a *side address*, bi-directional microphone and the rejection in the "dead" areas is very strong. Due to this directionality, ribbon microphones should be placed at 1.3 times the distance normally used with omni-directional microphones, or about the same distance used for cardioid microphones. This method is used to achieve the same ratio of direct to reflected sound.
2. In the horizontal plane, ribbon microphones do not discriminate against the "highs" off axis; nor do they boost them on axis. Therefore, several instruments or vocalists can be placed in front of the microphone without favoring the performer in the center of the group.

Several performers can be grouped at both the front and back of the microphone, with one proviso: Since the outputs are out of phase at the front and back of the microphone, cancellation can result if two tenors are placed at opposite sides at equal distances and they are singing in unison, so listen to the feed before committing to it.

2. When using a ribbon microphone with loud signal sources, placing the microphone slightly off axis to the signal source is all that is required for efficient operation.
3. The Royer model SF-1 requires no power supply and is safe to use on consoles with phantom microphone powering, provided that the cabling is properly wired. It should be noted that not all ribbon microphones are compatible with phantom-powering systems, so check the manufacturer's recommendations before using other ribbon microphones. It should also be noted that faulty or improperly wired cables could cause problems with your SF-1.
5. Never attempt to "test" the SF-1 or any ribbon microphone with an ohmmeter. A

blown ribbon could result.

6. Always provide adequate protection for your SF-1, or any ribbon microphone.
7. If the microphone is to remain set-up on a stand when not in use, place a “mic sock” over it until it is to be used. Do not carry the microphone around without placing a “mic sock” over it.

Failure to follow this commonsense practice may yield a stretched ribbon and compromised performance!

### ***Amplification Considerations***

The performance of a ribbon microphone is directly affected by the choice of microphone preamplifier it is paired with. With so many mic preamps on the market, how do you select one that gives the best possible performance with a ribbon microphone? Additionally, what kind of performance can we expect from the preamplifiers built into our mixing desks? While most preamplifiers will handle ribbon microphones well in most recording situations, some preamps that work perfectly well with condenser or dynamic mics may prove to be poor performers with ribbons.

To begin with, we must understand the fundamental differences between ribbon microphones and other popular types, namely condenser and moving coil dynamics. A ribbon microphone is actually a dynamic microphone that uses a flat, extremely low mass ribbon element, rather than a coil/diaphragm assembly. For this writing, any mention of “dynamic” microphones will relate to moving coil dynamics.

All condenser microphones have a built in preamplifier called a head amp and therefore put out a hefty signal. Because the signal is buffered through the head amp, the output impedance is rather low and less affected by the input impedance of the microphone preamp. Most dynamic (moving coil) microphones generate a healthy enough electrical current to work well with a variety of preamps, and their limited frequency response characteristics make mic loading less of a concern.

Ribbon microphones generate a highly accurate signal, but the average ribbon mic generates approximately 20 dB less gain than that of condenser microphones. Remember, the ribbon transducer does not have the benefit of a condenser mic’s built in “head amp”, so *a ribbon microphone relies solely on the microphone preamp for all its gain!*

The so called ideal preamplifier is the proverbial “straight wire with gain”. This may be considered the technological ideal and does not include “coloration” as a desirable feature. However, coloration is often desirable and has given rise to the popularity of certain preamps and even preamp stages in mixing desks. Neve® preamps and the famous Trident® A Range mixing console are highly praised for their classic sound.

*So what should we use with our beloved ribbon microphones? The features that translate into top performance for a ribbon microphone are the following:*

1. Lots of gain! A ribbon microphone works best with preamplifiers that have at least 60-70 dB of maximum gain.
2. Low noise is a must! With this much gain being required for efficient operation of a ribbon microphone, the noise characteristics of the preamp play a pivotal role in overall performance of the captured acoustic event.
3. Load characteristics: A suitable preamplifier should have input characteristics that impose the least amount of loading to the ribbon element. In other words, the input impedance should be high enough that its effect on the performance of the mic is negligible. A good rule of thumb is to have a preamplifier with input impedance at least *five times* the impedance of the microphone. For example: If the mic is rated at 300 Ohms (as Royer's are), the preamp should have an input-impedance of at least 1500 Ohms. If the impedance of the preamp is too low, the microphone will lose low end and body.
4. Transparency: A good preamp should sound natural with no edginess. Tube preamps sound warm, yet wonderfully transparent. Transformer coupled preamps sound punchy. When recording with condenser or dynamic microphones engineers often choose mic pre's that help "warm up the mic", but warming the signal up does not need to be a consideration with ribbon mics because they are by nature warm and realistic sounding. At this point personal taste should prevail over anything.

### *Stereo Microphones & Ground Loops*

Some preamplifiers are prone to developing ground loops when used in conjunction with stereo or multi channeled microphones, such as the SF-12. Ground loops can develop in the preamplifier with any stereo microphone, regardless of the type (i.e. condenser, dynamic, ribbon). A ground loop manifests itself as unwanted noise, buzz or hum (usually 120HZ).

The condition is brought on when the *left* and *right* transducer elements are plugged into two inputs of a stereo or multi-channel preamplifier. The pair of three-pin male XLR connectors of the stereo microphone cable usually shares Pin-1 as ground, so they are grounded to each other through the cable set. If the grounding scheme within the preamplifier is poorly designed, or the distances to internal ground are too great, a ground loop develops. The problem may be more apparent with ribbon microphones because of the high gain required for proper operation.

You can perform a simple test to check for this condition (preferably done with a pair of headphones to avoid feedback). Plug one side of the stereo microphone into either preamplifier input. Listen to the output of the preamp. All should be quiet except for the mic signal. Now plug the second side into the next preamplifier input. If a noise or buzz develops, you have a ground loop. The ground loop may be very slight or more pronounced, depending on the preamp. Battery powered preamps usually do not exhibit this problem, and neither do well designed, line operated mic pre's. The simple fix is to

disconnect one of the microphone's two Pin-1 ground connections. A better method is to make a small ground lifter out of a male-female XLR barrel adapter. Switchcraft makes a very nice one and it takes less than five minutes to wire it up. Simply connect Pin-2 to Pin-2, Pin-3 to Pin-3, and leave Pin-1 disconnected. Correcting the problem at the preamplifier would be preferable, but is often more difficult and/or expensive.

In conclusion, try to find the best preamp you can afford that has good gain characteristics and low noise. Coloration is optional.

### *Equalization and Ribbon Microphones*

One of the great strengths of ribbon microphones is how well they take EQ. Even with substantial amounts of equalization, ribbons retain their natural, "real" quality. For example, where a lead vocal is being performed on a ribbon microphone, you can actually boost the upper end frequencies to the point where the ribbon mic emulates the performance curve of a condenser mic with excellent results. This is not to say that a ribbon microphone can replace a quality condenser mic, but the EQ friendliness inherent in ribbon microphones does allow for an enormous amount of flexibility.

The reason that ribbon mics take EQ so well is because of their inherent low self-noise (less than 15 dB) and unusually smooth response characteristics. Dialing in high amounts of equalization on condenser or dynamic microphones also means dialing in extra amounts of the microphones distortion products and self noise; garbage that contributes to an unnatural, unpleasant sound. Because distortion and self-noise are almost non-existent in ribbon microphones, high levels of EQ can be used without adding harshness or excessive noise.

### *Hum, Noise & Mic Orientation*

All dynamic microphones, including ribbons, utilize powerful magnets in their motor assemblies and matching transformers, and are, to some degree, susceptible to picking up stray alternating magnetic fields. Power transformers (such as those found in guitar amplifiers) and alternating current motors are the most likely sources of radiated noise. Building wiring and electrical utility transformers are other likely sources. A well-designed microphone provides shielding to minimize the effects of stray magnetic radiation. In some cases complete isolation is impossible and the result is usually hum or buzz. Ribbon microphones can potentially manifest this condition to a greater degree because of their higher gain requirements. With vintage ribbon microphones that employ large bulky magnet structures, the problem can be worse.

Royer SF-1 and SF-12 microphones are designed to minimize the effects of unwanted radiation by integrating the transducer barrel as part of the magnetic return circuit. With this design, the barrel housing the transducer serves to complete the North-South magnetic return and neutralizes the effects of outside magnetic radiation. The SF-1 mono and SF-12 stereo ribbon microphones go one step further by incorporating toroid impedance matching transformers, which have a natural ability to repel magnetic radiation.

Dynamic and ribbon microphones are passive devices, meaning they incorporate no external or internal power supplies and have no head amplifier and therefore cannot

produce hum on their own. Unwanted noise (hum) can only come from an external source. Fortunately, there is a simple procedure that can be used to identify the source of the noise and eliminate it. Repositioning a dynamic and ribbon microphone is the number-one way to get rid of unwanted noise. If hum is detected, it means that the microphone is in the proximity of an alternating magnetic field. While listening (preferably with headphones) to the mic, move it around. The mic will “find” the noise source quite easily. If you are miking a guitar amplifier and suspect the amplifier’s power transformer may be the source of unwanted noise, move the mic around the amp. You will probably find that the noise is louder as you approach the amplifier’s power supply and quieter when you move it away. Eliminating the noise can be fairly simple and requires finding the “null” point of the noise. The “null” point is the position that places the microphone’s magnetic components away from the lines of radiation. Simply rotating the microphone slightly is many times all that is required to cancel out the noise. This is similar to the procedure guitarists use to eliminate noise from single coil guitar pickups. There will be a “magic position” where the noise disappears completely. Finding the exact position that also provides acceptable acoustic placement of the mic requires a little practice, but the results are well worth the time.

### ***The Sweet Spot*** *Finding and Working with the Sweet Spot*

Good engineers know the importance and benefits of finding and working with the “sweet spot” of a given microphone. The sweet spot will be defined as the optimum placement (working distance and angular position) of any microphone relative to the sound source.

Each microphone has its own sweet spot whether it is a ribbon, dynamic or condenser type. The sweet spot will vary with the type of sound source and its volume intensity, the polar pattern of the microphone and how consistent it is with frequency and the acoustic environment.

This condition is called the sweet spot because the microphone and the sound source are in a harmony of sorts; the acoustic information is exciting the microphone in such a fashion that the resulting reproduction is very desirable, usually without the need for additional equalization or electronic manipulation.

There are only general rules as to where the sweet spot may be found for any given microphone, and usually experimentation reveals it. The sweet spot can be extremely variable since it depends on the quirks of a given microphone and a given room. Once the sweet spot is discovered, this placement can become a rule of thumb starting point for future microphone placement with similar sound sources. Remember this: *If it sounds good, it’s probably right.* If it doesn’t, move the microphone. It’s often more effective to reposition the microphone than to start fiddling with knobs. Knob twisting can affect headroom and phase coherency and add unwanted noise.

*The following is a list of variables that contribute to “sweet spot” effect.*

1. Frequency response variations due to proximity effect.

2. Frequency response variation due to treble losses as a result of absorption and narrowing of the pattern at high frequencies-causing weakening of highs as the microphone is moved away from the sound source.
3. Rise in treble response on-axis due to diffraction.
4. Loss of treble response off-axis due to phase-loss effect.
5. Variation in ratio of direct to reverberant sound.
6. Tendency of a microphone to favor the nearest sound source due to a combination of these items, plus the influence of inverse square law.

### *Other Types of Microphones*

For the same ratio of direct to reverberant sound, omni-directional microphones must be closer to the sound source than cardioid or bi-directional microphones. Microphones should generally face the sound source head-on or else treble loss due to phase loss will result. The exception here is for large condenser microphones, which often give the flattest response at an angle of about 10-20 degrees (off axis), where phase loss and diffraction effect offset each other somewhat.

### ***Proximity Effect and Working Distance*** *The Sound That Is "More Real than Real"*

Ribbon microphones have long been renowned for rich bass. This effect is largely due to the fact that ribbon microphones generally have excellent bass response to begin with, and at the same time exhibit an effect known as "proximity effect" or "bass tip-up."

As illustrated in the following graph, a typical bi-directional ribbon microphone will have a flat frequency response at a distance of about six feet from the microphone but at shorter distances the bass response becomes boosted; the effect becomes increasingly pronounced as the distance between the microphone and the sound source is reduced.

This bass-boosting characteristic can become quite intense and, if desired, can be corrected by equalization. However, for a multiple microphone setup, the pronounced bass boosting (due to proximity effect) can be turned to an advantage. If an instrument such as a trumpet is extremely close miked and the bass is cut to restore flat response, unwanted low-frequency sounds are cut back by upwards of 20 dB compared to an unequaled microphone with a flat response; and this discrimination is *independent* of the microphone's polar response.

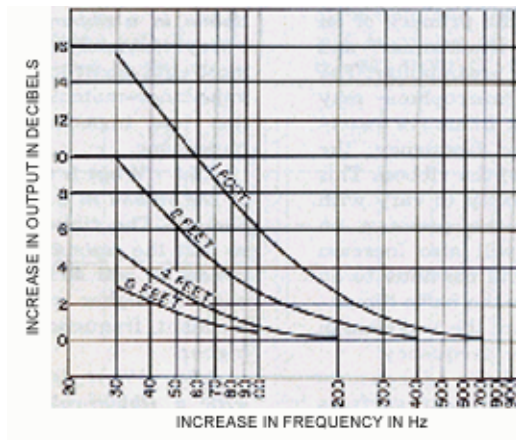

*Typical relationship of microphone distance to frequency response for ribbon-velocity bi-directional microphone.*

Another area where proximity effect can be turned to an advantage is in making things sound “more real than real.” For example, many voices and certain musical instruments produce fundamental frequencies within the bass range (below 150HZ or so) but the fundamentals are weak. In a worst case, if a microphone which has no proximity effect and a rising high frequency response is used on an upright piano, or on a person with a thin, weak voice, the recorded sound is likely to sound even thinner than it was in real life. In contrast, using a microphone with strong proximity effect on such sound sources can result in a “better than real” sound since the boosted bass response will compensate for the weak fundamentals in the sound source. Since the fundamentals are present, but weak, boosting them by several dB will sound “natural,” even though the sound has been “sweetened.”

Radio and television announcers have long relied on proximity effect to produce a full, rich, authoritative quality to their voices. By knowing how to work with the proximity effect, the engineer can get several useful effects without resorting to electronic manipulation.

### ***Microphone Technique*** *General Tips for Using Ribbon Microphones*

**Brass Instruments** and ribbon microphones go together very well. Mic the instrument from a distance of a couple of feet, and increase the working distance a little if several instruments are being used.

**Reed Instruments** sound full and never edgy when captured with a ribbon microphone. Normal working distances are about a foot or two from the instrument.

**Strings** sound very sweet and clean with ribbon microphones. Place the microphone several feet from the instrument. For larger string sections, place the microphone slightly above the instrumentalists and angled down; a distance of three or four feet will do the trick nicely.

**Pianos** sound excellent with ribbon microphones and are free of phase-related comb filtering. The bass is full and rich while the top remains clean with no clatter. Mic the

piano at a distance of one foot to several feet, depending on taste. A more direct up front sound will be achieved when the microphone is placed closer to the soundboard.

For capturing a piano in stereo, place the microphones apart, one over the bass strings and the other over the high strings. The farther the mics are from each other, the wider the stereo spread. For a more direct stereo effect, the microphones may be placed in an “X” pattern a couple of feet from the center of the soundboard.

It is often worthwhile to remove the piano lid and suspend the microphone(s) above the soundboard for the most natural sound. When mics are placed inside a piano with a raised lid, the sound reflecting off the lid may be undesirable.

**Amplified Instruments** should be miked from a distance of a foot or more. The smooth, undistorted low-end response is very useful for electric guitars.

Since guitar amplifier speakers are often beamy, experiment with mic placement to find just the right spot. Placing the mic at greater distances from the speaker cabinet adds more room ambience to the mix. You will find that a ribbon microphone does not add undesirable elements to the sound. Basically, what you hear is what you get.

**Choirs and Orchestras** can be picked up very well with two microphones. Place the microphones at a distance of ten feet from the floor, and a few feet behind the conductor. The microphones should be spaced apart approximately one foot and angled, one toward the left and one toward the right.

**Drums and Percussion** instruments sound very natural when microphones are placed at a distance of several feet. For a drum set, placing the microphone(s) at a distance of four to six feet above the kit works very well without the cymbals sounding “splashy.” The SF-1 is not recommended for use as a kick drum mic.

## ***Stereophonic Microphone Technique***

### **Classic Blumlein technique**

For many years, several “coincident” microphone setups have been widely used for picking up sounds in stereo as naturally as possible.

The “Blumlein” technique, named for A.D. Blumlein of England, involves the use of two figure-eight microphones positioned as in the sketch (*see Figure 1*); so that one faces left and the other, right, at an angle of 90° (i.e. each displaced 45° from center).

Each microphone ultimately feeds one speaker in a stereo system, and due to the directionality of the microphones, the result is a very well defined stereo effect on playback. For classical music, particularly, the reproduction can be very satisfying.

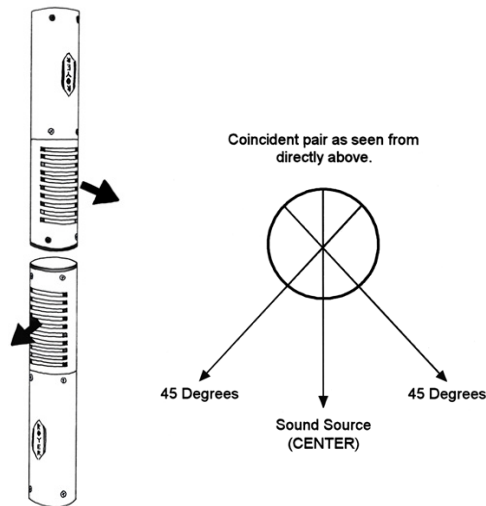

Figure 1  
Classic Blumlein or “coincident miking  
technique

### Mid-Side Technique:

In the early days of stereo radio broadcasting, there was a need for a mic setup that would allow for simultaneous stereo and mono feeds from the same mic array and for electronic fiddling with the severity of the stereo effect.

The result was what is known as the mid-side microphone technique. One mic faces sideways, one faces forward as shown in Figure 2, and they are connected as shown in Figure 3.

When the outputs of the pair of microphones are combined at the mixer, they will behave like a pair of microphones, one facing left and one right, provided that the sensitivities of the mics are equal and the mixer channel gains are equal.

Turning down the side mic all the way will give a mono pickup; as the side mic is turned up, the stereo effect will gradually appear.

If the outputs of the mid and side microphones are recorded on separate tracks, the electrical connections shown in Figure 3 could be made at the mixer outputs and the adjustment of the stereo separation could be done during mixdown, rather than during the actual recording - very useful for live recording.

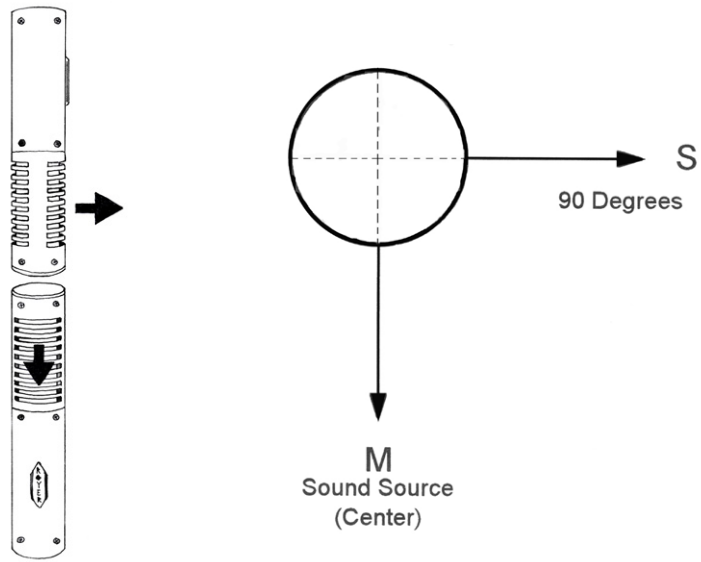

Figure 2 – Typical M-S miking technique

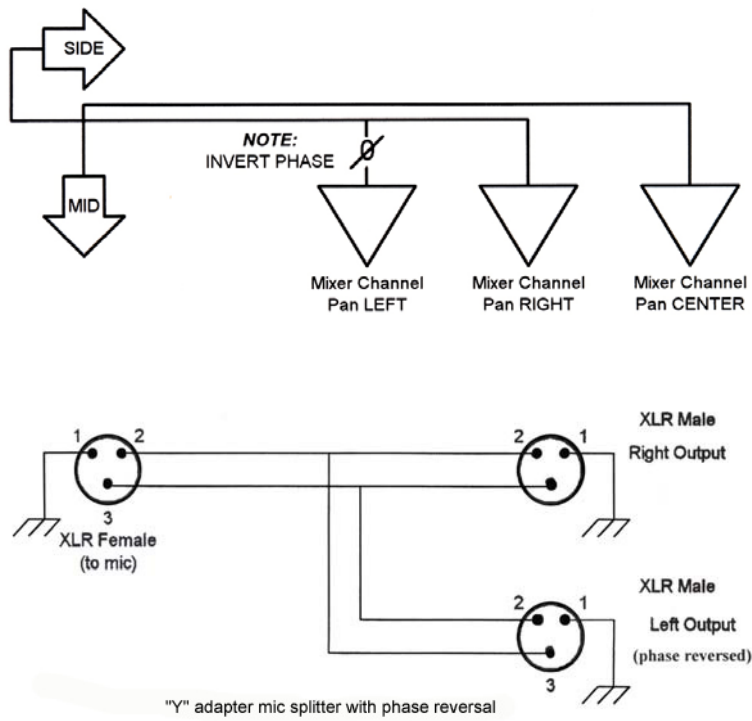

Figure 3 – Typical M-S connection set-up

## ***Care and Maintenance***

The SF-1 is a well-built precision instrument. All that is required to ensure proper operation of this microphone is to follow some commonsense rules.

1. Avoid transducer damage by not exposing the microphone to severe shock or vibration. If the microphone is accidentally dropped, test it to see if damage has occurred before returning it to service.
2. Do not expose the microphone to direct blasts of air. Use a windscreen or suitable blast filter when close miking a vocalist or certain types of wind instruments. P-popping does not necessarily damage the ribbon element but may produce unacceptable preamplifier overload and could cause damage to speaker systems.
3. Do not expose microphone to liquids or caustic smoke.
4. Do not expose the microphone to strong alternating electromagnetic fields, i.e. the power transformers in amps, or a hum may result.
5. Use a soft cloth to clean the microphone body. A small amount of denatured alcohol can be used to remove fingerprints and other stains.
6. Keep metal filings away from the microphone at all times.
7. When not in use, store the microphone in its protective wooden case.
8. Leave disassembly of the microphone to a trained technician. There are no user-serviceable parts inside.

### ***Caution!***

***Keep recorded tapes, spring-wound watches, and personal credit cards using magnetic coding away from the microphone to prevent possible damage caused by the transducer's magnets.***

## ***A Little Bit of History***

The ribbon-velocity microphone design first gained popularity in the early 1930s and remained the industry standard for many years. Their characteristic sound signature can still be appreciated today in recordings of the 30s, 40s, 50s and early 60s.

Ribbon microphone development reached its pinnacle during this time. Though they were popular with announcers, one of the disadvantages of ribbon microphones was their immense size. Even though these devices were considered state-of-the-art, magnetic structures of the time were bulky and inefficient. Transformers suffered a similar deficiency. When television gained popularity in the late 1940s, it was obvious that their size was intrusive and objectionable. They were difficult to maneuver and broadcasters soon looked for a suitable replacement. Even though these microphones performed very well, their days were numbered. Newer dynamic and condenser mics would soon replace

them. The new designs were compact, rugged and sensitive. It wasn't long before the television industry embraced these new designs. Radio followed the trend shortly afterward. Further technological development of ribbon microphones was considered unnecessary and the beloved ribbon soon faded into obscurity. It is a fate reminiscent of that of the vacuum tube when transistors hit the scene.

Some of their unique characteristics, unmatched even by today's modern condensers and dynamics, are still revered by many professionals, as evidenced by the high prices that vintage ribbons command in the marketplace.

Traditional-style ribbon microphones are still being manufactured in limited quantities today by a few companies. These microphones are essentially similar to the designs of the 1930s and limited to specialized applications.

Recent developments in magnetics, electronics and mechanical construction procedures have made it possible to bring the ribbon microphone back to the forefront of the audio field. This is similar to the resurgence vacuum tubes have made in recent years, now that technology has enabled further development of the state of the art in numerous areas. A renewed interest in these designs (both tube technology and ribbon microphones) is driven by the unique characteristics these devices possess, which remain unmatched even by some of today's marvels.

Today's ribbon microphones can be made smaller, and have sensitivity levels matching those of modern dynamic microphones. Aside from the superlative audio qualities of these microphones, their smooth frequency response and phase linearity make them ideally suited for the new digital formats that dominate the industry today.

### ***Features and Specifications***

- Very high overload characteristics – maximum SPL greater than 130 dB
- No internal active electronics to overload or produce distortion up to maximum SPL rating
- Extremely low residual noise
- Ribbon element is unaffected by heat or humidity
- Absence of high frequency phase distortion
- Excellent phase linearity – even off axis
- Equal sensitivity from front or back of element
- Consistent frequency response regardless of distance
- No power supply required
- Compact size

## ***Electrical Specifications***

Acoustic Operating Principle:	Electro-dynamic pressure gradient
Generating Element:	1.8 micron aluminum ribbon
Polar Pattern:	Figure-8
Frequency Range:	30 HZ – 15,000 HZ
Sensitivity:	-54 dBv Ref 1 Volt per Pascal (+ or -) 1dB
Output Impedance:	300 Ohms (nominal) balanced
Rated Load Impedance:	> 1500 Ohms
Maximum SPL:	> 130 dB SPL
Output Connector:	Male XLR 3 pin (Pin 2 Hot)

## ***Mechanical Specifications***

High grade Neodymium magnet assembly 1.25” x .0625” x 1.8 micron ribbon assembly	
Stainless steel internal baffle and dampener	
Weight:	264 grams (9.3 oz.)
Dimensions:	142 mm x 25mm
Finish:	Matte black chrome
Accessories:	Protective wood case, documentation, complimentary mic clip
Optional Accessories:	Shock mount, windscreen
Warranty:	Unconditional (repair or replace at Royer’s option)

## ***Polar Pattern***

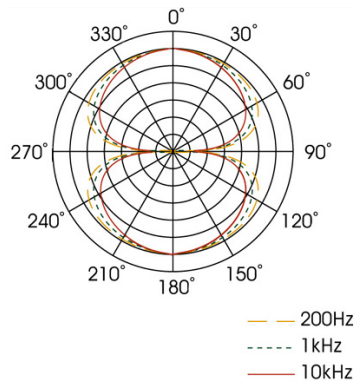

## ***Frequency Response***

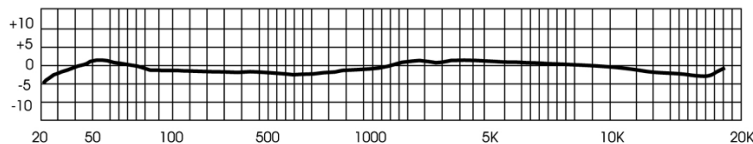

### **Warranty**

Royer Labs warrants its products to be free from defects in materials or imperfect workmanship. This warranty is offered to the original owner without time limit. Royer Labs will repair or replace any product that fails to meet published specifications during the warranty period. This warranty does not apply if the product has been damaged by accident or misuse, or as a result of repair or modification by other than a Royer Labs customer service facility authorized to service this product. To validate this warranty, the registration card and a photocopy of the sales receipt from an authorized Royer Labs dealer must be on file with Royer Labs. Should it ever become necessary to service your Royer Labs product, please contact the factory. In our continuing effort to improve our products, Royer Labs reserves the right to make improvements without notice or obligation. Specifications and prices are subject to change without notice or obligation.

**Serial Number** \_\_\_\_\_

**Sensitivity** \_\_\_\_\_ **Resonance** \_\_\_\_\_

**Date of Purchase** \_\_\_\_\_

**ROYER Labs**  
821 North Ford Street  
Burbank, California 91505  
Telephone 818.760.8472  
Fax 818.760.8864  
www.royerlabs.com

**Polar Pattern**  
**Frequency Response**  
Notes: